



GENUINE PARTS

INSTALLATION INSTRUCTIONS

- 1. DESCRIPTION:** Illuminated Kick Plate Kit
- 2. APPLICATION:** Murano
- 3. PART NUMBER:** 999G6 C2000, 999G6 C2100, 999G6 C2200
999Q9 AY001 - Accessory Service Connector

4. KIT CONTENTS:

Item	QTY	Description	Service Part Number
A	1	Illuminated Front Kick Plate (RH)	Not Serviceable- Part of Kit 999G6 C2x00
B	1	Illuminated Front Kick Plate (LH)	
C	1	Non-Illuminated Rear Kick Plate (RH)	
D	1	Non-Illuminated Rear Kick Plate (LH)	
E	22	Cable Tie	
F	4	Posi-Tap	
G	8	Foam Tape	

ITEMS NOT IN KIT THAT MAY BE REQUIRED

2	Accessory Service Connector	999Q9 AY001
---	-----------------------------	-------------

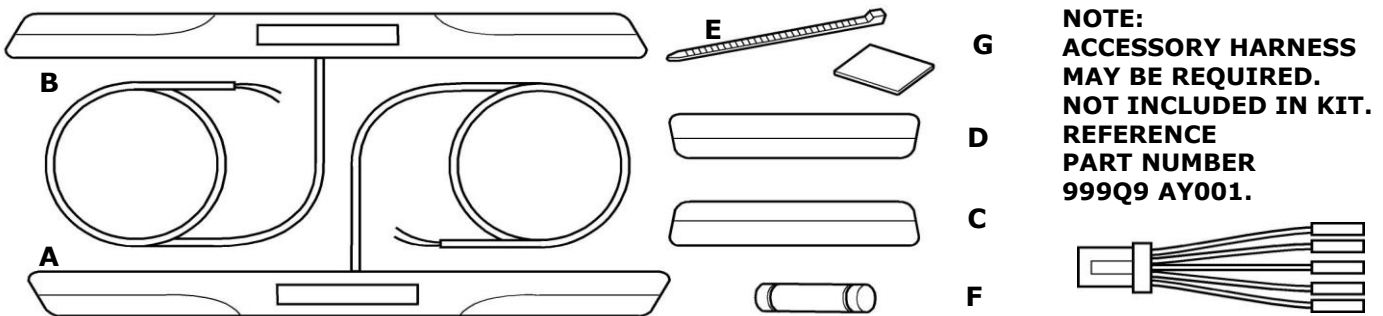

5. TOOLS REQUIRED

- Trim removal tool
- 50/50 alcohol & water solution
- Protective gloves
- Electrical tape
- Protective cloth
- Torx screwdriver, T-20
- Wire cutting pliers

6. PRE-INSTALLATION CAUTION/NOTES

- Dealer installation recommended. Instructions may refer to Service Manual
- Installation may require special tools
- This part is to be installed within a surface temperature range of 60-110°F

⚠ CAUTION

- This accessory must only be installed as specified in these instructions.
- Ensure at all times that parts are securely fitted and will not compromise the safe function of vehicle systems.

INSTALLATION INSTRUCTIONS - Illuminated Kick Plate Kit

7. INSTALLATION OVERVIEW

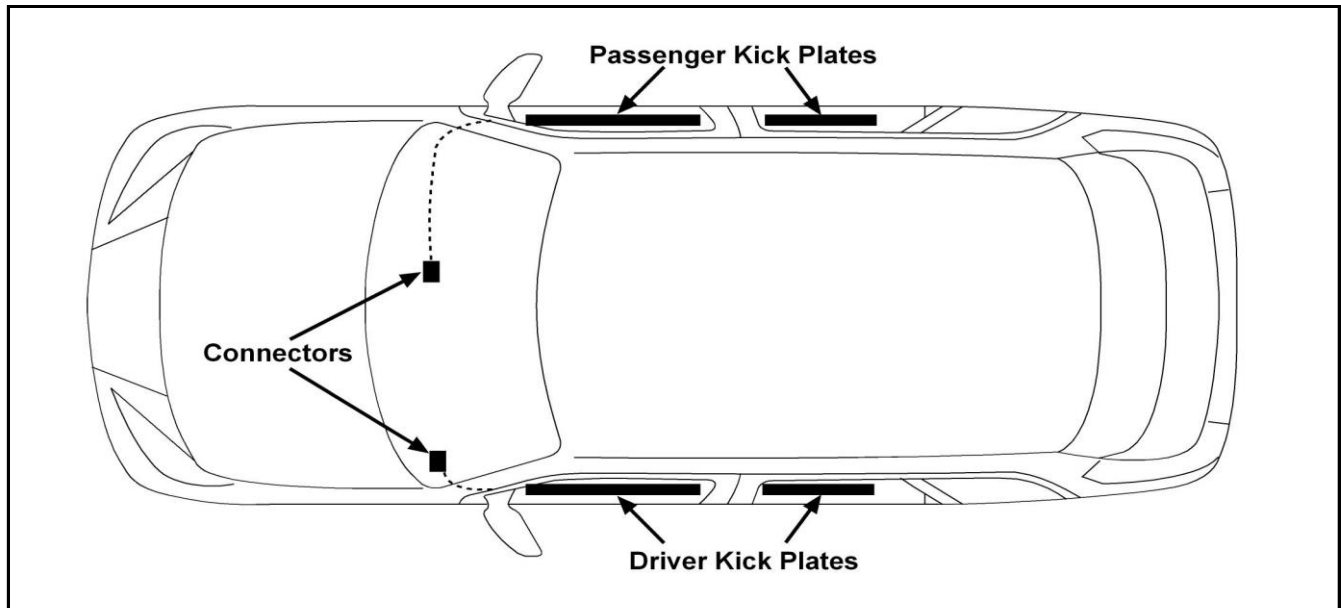
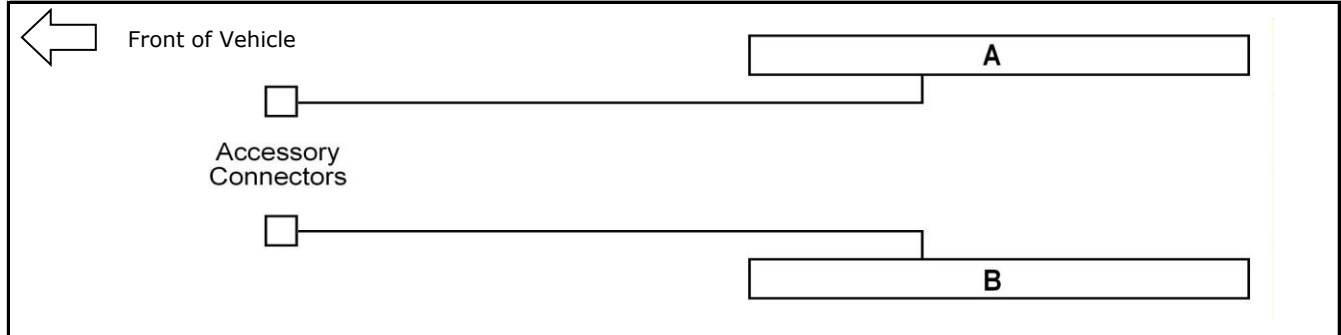

⚠ CAUTION

CRITICAL STEPS TO DISCONNECT BATTERY:

- Allow 3 min after key off and doors closed for vehicle to time out (if doors are opened again additional time may be required). Disconnect negative terminal. Allow an additional 3 min after negative terminal disconnect before separating any electrical connectors.

8. CRITICAL STEPS

The following steps are critical and must be performed **EXACTLY** as specified to ensure proper installation:

- Posi-Tap™ instructions must be specifically followed as described.
- Be sure to apply masking tape as needed in order to protect any areas that may become scratched or damaged by tools.
- Be sure to apply foam tape to any wiring components that can be damaged over time by sharp edges.
- Test the functionality of the kit before final clean up and reinstallation of interior panels.

INSTALLATION INSTRUCTIONS - Illuminated Kick Plate Kit

9. VEHICLE PREPARATION:

- 1) Apply parking brake
- 2) Confirm the vehicle is no longer in the default shipping state (Extended Storage Switch Pulled Up and BCM in Transit Mode). Failure to confirm the vehicle has been removed from this state will result in the loss of normal vehicle operation.
- 3a) Locate the Extended Storage Switch in the cabin fuse block. Once located, check that it is in the "Customer" position. See below for reference.

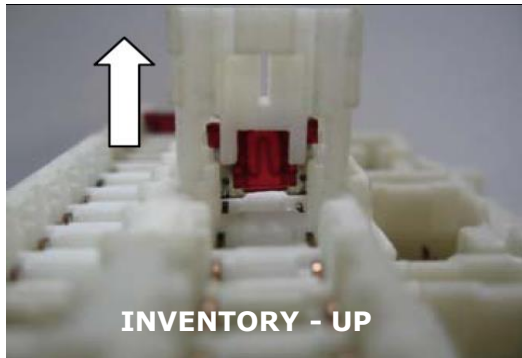
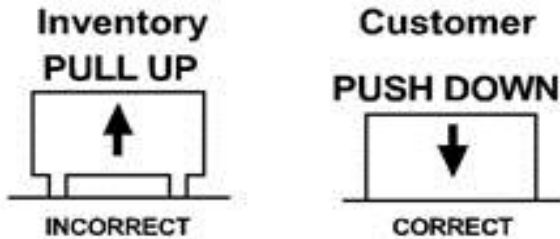

3b) To remove transit mode:

1. Remove fuse cover lid
2. Push down shorting pin
3. Ign On 2 times without turning vehicle on

To return to transit mode:

1. Ign Off
2. Remove fuse cover lid
3. Pull up shorting pin
4. Assemble fuse cover lid
5. Ign On 2 times without turning vehicle on
6. Confirm transit mode condition on meter

NOTE: Typical vehicle condition shown here. Switch is easily identifiable by the permanent, push-pull fuse holder. Actual position on the fuse block may vary, vehicle to vehicle.

- 4) Record customer radio presets.

	1	2	3	4	5
A					
B					
C					

NOTE: USE CAUTION WHEN REMOVING / RE-INSTALLING TRIM COMPONENTS TO AVOID DAMAGE, SCRATCHES, BREAKING OF CLIPS AND / OR INTERIOR TRIM PANELS. MOVE ALL TRIM COMPONENTS TO A PROTECTED AREA.

⚠ WARNING

FOR VEHICLES WITH MANUALLY OPERATED SEATS
Disconnect negative battery terminal before proceeding.

FOR VEHICLES WITH POWER SEATS
Disconnect negative battery terminal AFTER Step 5

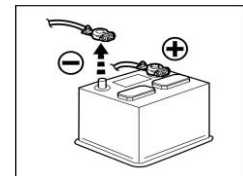

10. Order of Installation

1. Remove panels and trim.
2. Install Kick Plate Assemblies
3. Route Wiring
4. Reinstall all panels

INSTALLATION INSTRUCTIONS - Illuminated Kick Plate Kit

11. INTERIOR PREPARATION

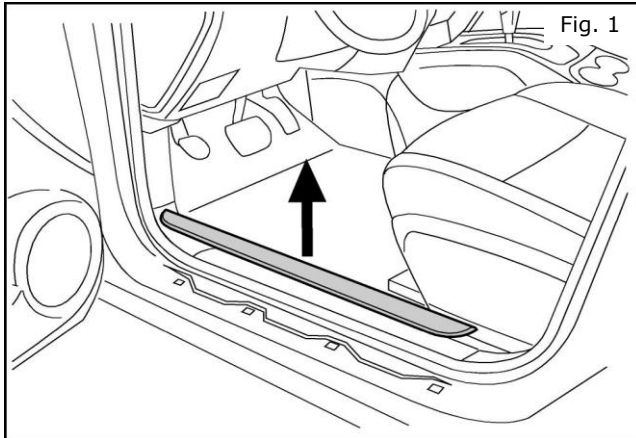

BEGIN ON DRIVER SIDE

1. Use a trim stick to carefully pry off the existing kick plate.

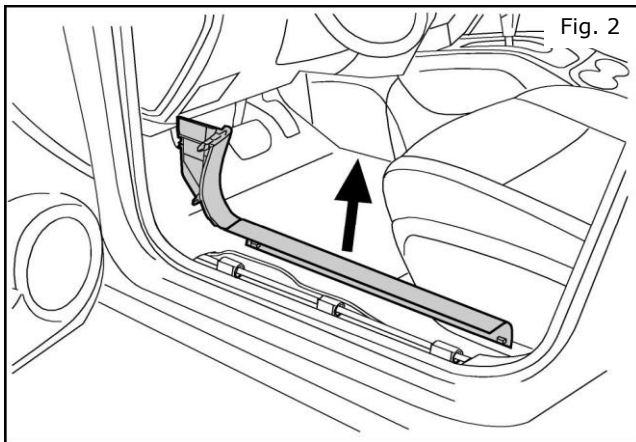

2. Move seat rearward. Remove inner door sill and footwell trim panel.

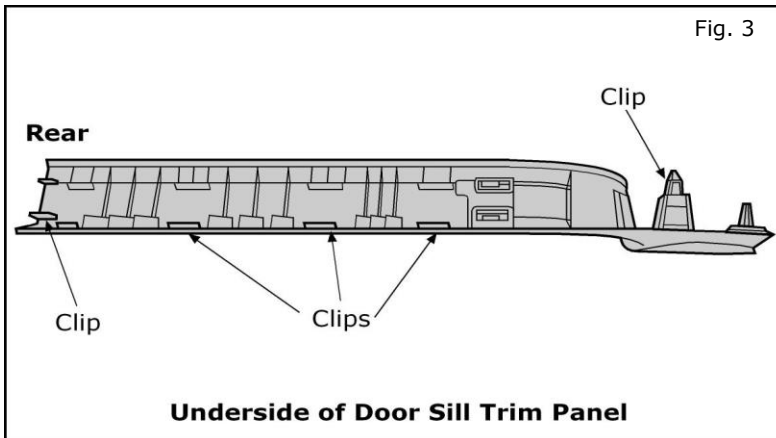

3. Place fingers at rear inside clip and pull out with a slight rotating motion until clip is popped loose, then pull up from rear to remove door sill trim panel.

INSTALLATION INSTRUCTIONS - Illuminated Kick Plate Kit

12. INSTALLATION

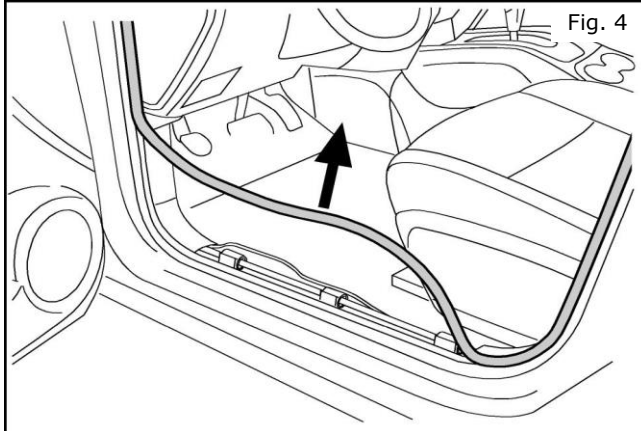

4. Carefully pull up the door seal welt from bottom of dash to back of sill plate as shown.

5. **REPEAT STEPS 1 THROUGH 4 FOR PASSENGER SIDE (RH).**

⚠ FOR VEHICLES WITH POWER SEATS

Disconnect negative battery terminal at this time.

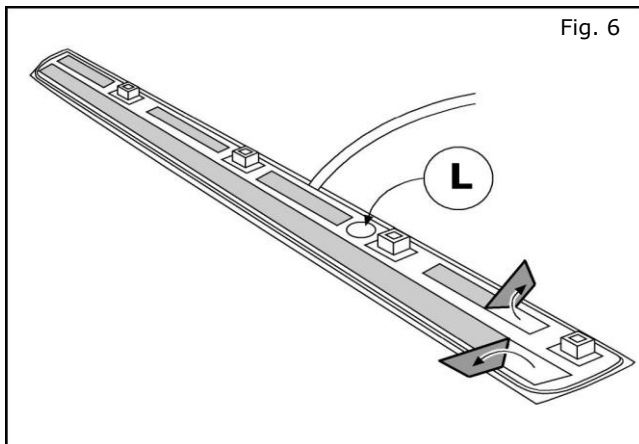

DRIVER SIDE INSTALLATION

6. Carefully flip the driver Kick Plate over. Partially peel away enough of each adhesive liner to fold down a "flag" that will extend beyond the outer edge of the Kick Plate. **Driver side kick plate will be marked with an "L"**

NOTE: Clean all mounting surfaces with alcohol wipe before final installation.

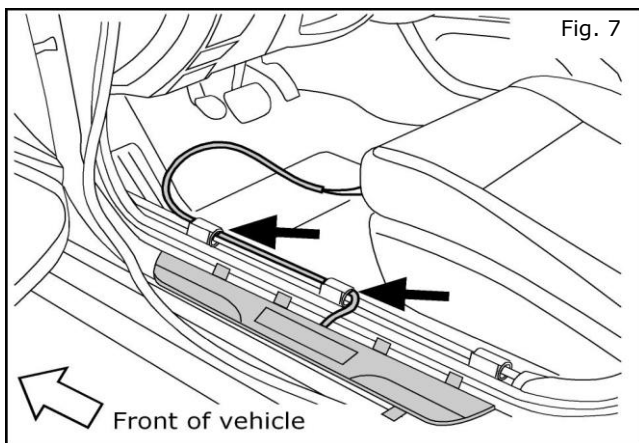

7. Place Illuminated Kick Plate into position on the driver side door sill by aligning the clips with the mounting holes in the door sill.

Do not snap the clips into place or attempt to close the door at this time.

Feed the end of the wiring up through the existing harness clips towards the footwell.

NOTE: Do not remove clear protective film until procedure is complete.

INSTALLATION INSTRUCTIONS - Illuminated Kick Plate Kit

13. POSI TAP INSTRUCTIONS

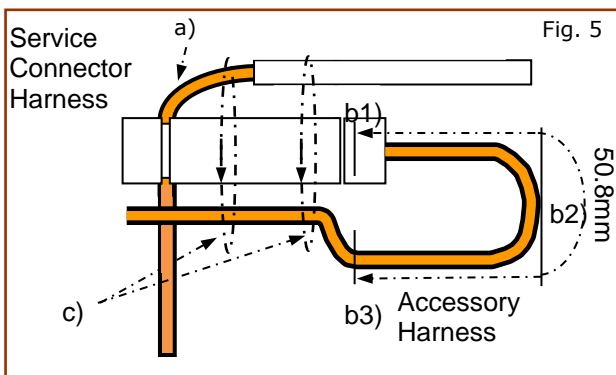
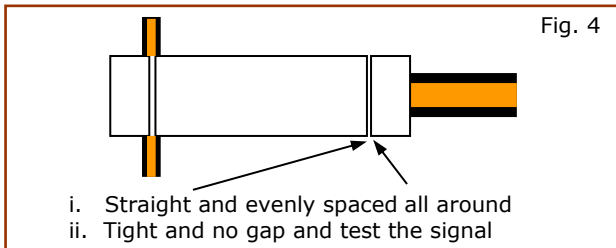
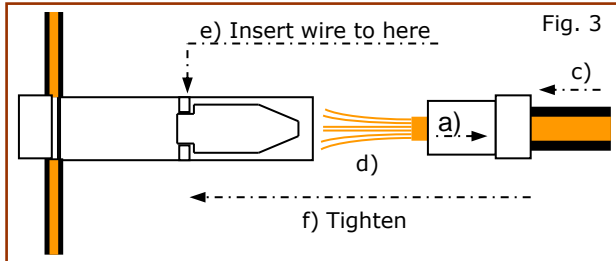
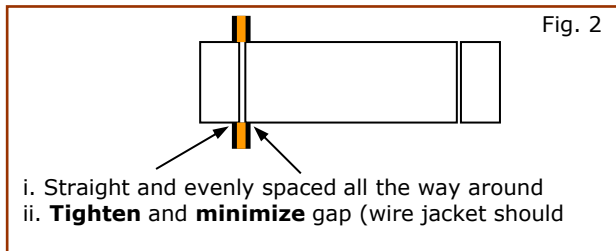
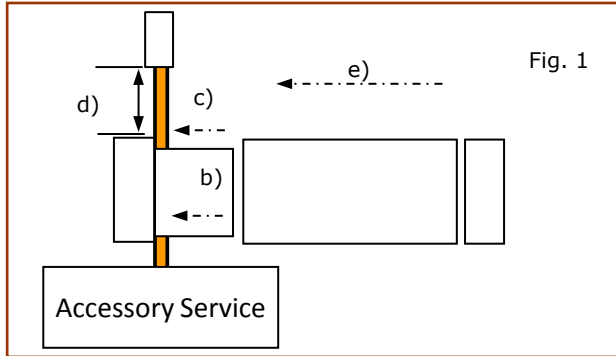

- 1) Tap Accessory service wire.
 - a) Identify and confirm correct wire in the Accessory Service Connector to be tapped.
 - b) Remove cap (slot side) from tap body.
 - c) Slide cap around single accessory wire.
 - d) Position cap $\geq 6.35\text{mm}$ (0.25 in) away from the heat shrink end of Accessory Service Connector (measurement for first posi-tap installed on the circuit).
 - e) Tighten the tap TIGHT with finger pressure.
 - f) Tighten by another quarter turn.

NOTE: Figures are not to scale.

- 2) Inspect the tap to ensure correct installation.
 - a) Pull on the wire lightly to ensure connection.
 - b) Inspect the tap to ensure correct installation.
 - c) Test the signal to ensure that it is working properly.

NOTE: Avoid putting pressure on the vehicle wire and tap for the remainder of the installation.

- 3) Tap accessory wire.
 - a) Remove tap (non-pierce) side from tap.
 - b) Remove the protective stub from the wire.
 - c) Insert wire through the non-pierce side opening.
 - d) Spread the individual strands into fan shape.
 - e) Insert wire into the tap body and ensure that it is all the way in.
 - f) Tighten the tap TIGHT with finger pressure.
 - g) Tighten by another quarter turn.

- 4) Confirm the tapped accessory wire.
 - a) Pull on the wire lightly to ensure connection.
 - b) Inspect the tap to ensure correct installation.
 - c) Test the signal to ensure that it is working properly.

- 5) Forming strain relief loop (always required)
 - a) Gently bend the end of the pierced wire (where it exits the cap) down towards body of posi-tap.
 - b) On the tapped wire of the non-pierce side; starting at point b1), measure 50.8mm (2in) to point b3). Make the first bend of the loop b2), half the distance measured 25.4mm (1in), and up toward the body of the posi-tap, make the second bend of the loop b3) in towards the posi-tap so it can be secured with electrical tape.
 - c) Secure the pierced wire on the heat shrink side and the tapped wire on the non-pierce side to the body of the tap with electrical tape (≥ 2 revolutions).

INSTALLATION INSTRUCTIONS - Illuminated Kick Plate Kit

13. POSI TAP INSTRUCTIONS

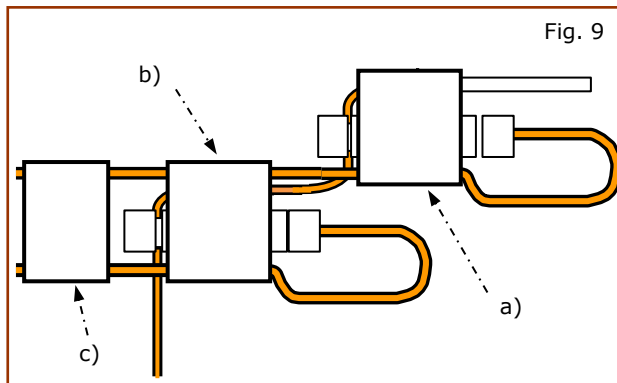
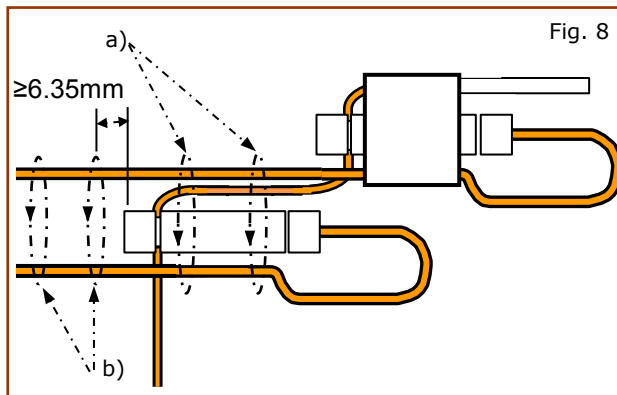
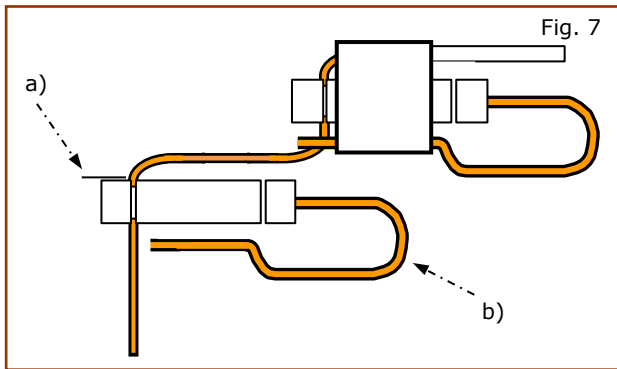
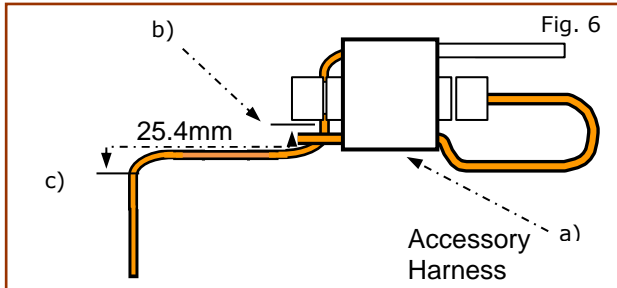

NOTE: If securing multiple taps to single circuit, continue to Step 6, if tapping different circuits repeat steps 1-5 as required, then proceed to step 10

- 6) Multiple posi-taps on the same wire; first tap
 - a) The first accessory is tapped, relieved and secured as shown in Fig 1 thru 5 (these steps are always the same).
 - b) Measure 25.4mm(1in) from point b) to point c) on the pierced wire.
 - c) At points b) & c), bend the pierced wire gently to form the "staircase" shape.
- 7) Multiple posi-taps; second accessory.
 - a) Tap second accessory at point b), making sure to preserve "staircase shape".
 - b) After tapping second accessory, form a strain relief loop for the tapped wire on the non-pierce side as shown in Fig c) and detailed in step 5b.

NOTE: Do not secure before reading step 8. Repeat as necessary.

- 8) Securing multiple posi-taps on the same circuit
 - a) Secure the pierced and tapped wires from the first posi-tap, along with the tapped wire from the non pierce side of the 2nd posi-tap to the body of the 2nd tap with electrical tape (≥ 2 revolutions).
 - b) Secure the tapped wires from the non-pierced sides of each tap to each other with electrical tape (≥ 2 revolutions) at a distance of $\geq 6.35\text{mm}(0.25\text{in})$ from the head of last posi-tap shown in Fig b).

Note: Repeat as required

Note: No single wire should be posi-tapped more than four times to maintain integrity.

- 9) Multiple accessory taps on the same circuit secured.
 - a) The first accessory is tapped, relieved and has the pierced wire on the heat shrink side and the tapped wire on the non-pierce side secured to the first tap as shown in Fig a).
 - b) The second accessory is tapped, relieved and has the pierced wire, the tapped wire on the non-pierce side and the tapped wire from the non-pierce side of the first posi-tap secured to the second tap as shown in Fig b).
 - c) Finally the tapped wires on the non-pierce

INSTALLATION INSTRUCTIONS - Illuminated Kick Plate Kit

13. POSI TAP INSTRUCTIONS

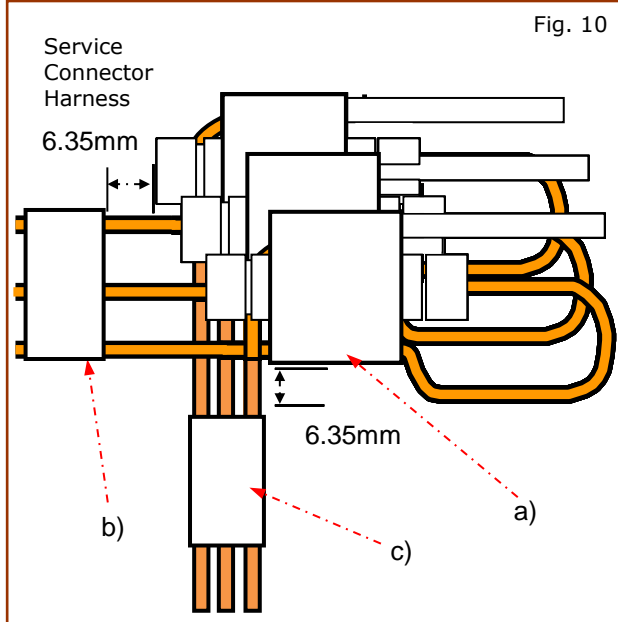

10) Multiple accessory taps on different circuits secured together.

- a) The tapped accessories (with wires already secured to tap bodies) are stacked slightly staggered on top of each other as shown in Fig a).
- b) The tapped wires on the non-pierce side of all the posi-taps are secured to each other with electrical tape (≥ 2 revolutions) at a distance of $\geq 6.35\text{mm}$ (0.25in) as shown in Fig b).
- c) The pierced wires of the first and subsequent posi-taps are secured to each other with electrical tape (≥ 2 revolutions) at a distance of $\geq 6.35\text{mm}$ (0.25in) as shown in Fig c).

INSTALLATION INSTRUCTIONS - Illuminated Kick Plate Kit

14. ACCESSORY CONNECTOR MECHANIZATION

⚠ CAUTION

This Accessory Service Connector is for use only with Genuine Nissan (or Infiniti) or Nissan (or Infiniti) approved accessories. Use of this connector with non Genuine Nissan (or Infiniti) or Nissan (or Infiniti) approved accessories or failure to follow the installation instructions for the connector contained in this package may result in damage to the accessory and/or your vehicle. Nissan (or Infiniti) is not liable for loss or damage due to improper installation or the installation of non Genuine or non approved accessories.

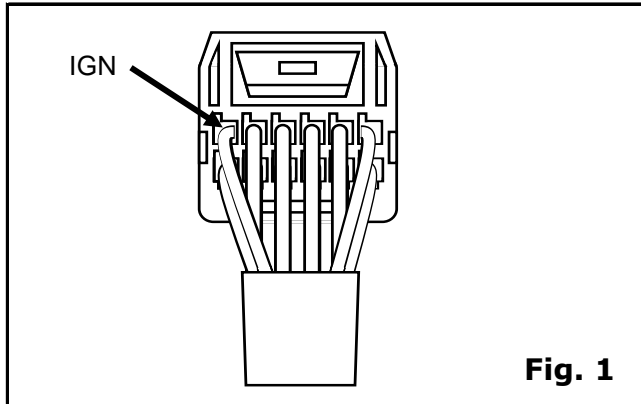

Fig. 1

ACCESSORY SERVICE CONNECTOR NOT INCLUDED IN KIT. REFERENCE PART NUMBER 999Q9 AY001.

999Q9 AY001		
Pin	Label	Color
1	IGN	WHITE
2	BAT	RED
3	TL_LMP	PURPLE
4	RM_LMP	YELLOW
5	BATSVR	PINK
6	FR_DR_SW_RH	DK GRN
7	FR_DR_SW_LH	LT GRN
8	THRU_SIGNAL_1	GREY
9	RR_DR_RH	DK BLUE
10	RR_DR_LH	LT BLUE
11	ACC	ORANGE
12	GND	BLACK

Use posi-taps to connect the wiring as follows:

DRIVER SIDE CONNECTIONS

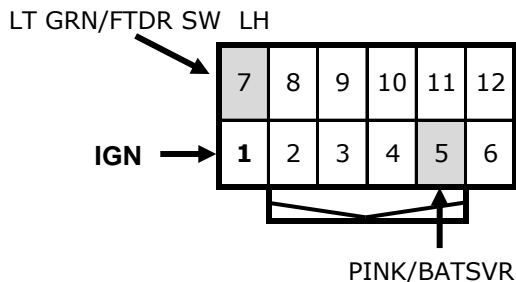

Red wire from the IKP Harness to the **Pink** wire on the Accessory Service Connector Harness.

Black wire from the IKP Harness to the **LT GRN** wire on the Accessory Service Connector Harness.

PASSENGER SIDE CONNECTIONS

Pin location is referenced looking into face of connector

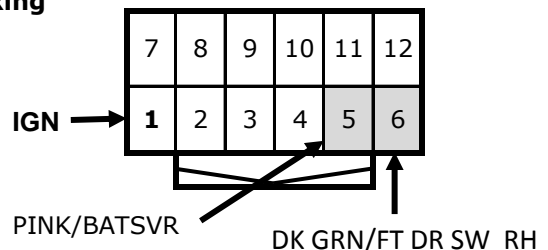

Red wire from the IKP Harness to the **Pink** wire on the Accessory Service Connector Harness.

Black wire from the IKP Harness to the **DK GRN** wire on the Accessory Service Connector Harness.

INSTALLATION INSTRUCTIONS - Illuminated Kick Plate Kit

15. INSTALLATION

⚠ CAUTION

- If a vehicle wire is being used by another accessory and a posi-Tap is present, tap the accessory wire NOT the vehicle wire.

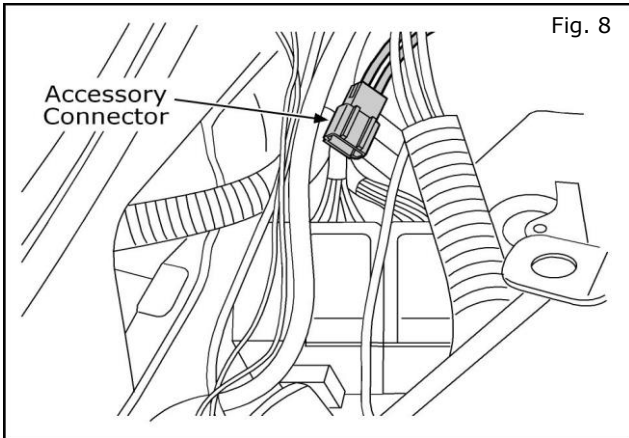

8. Locate the **driver side** Accessory Connector plug. It will be located up under the dash in the area shown near the A-pillar.

NOTE: A previously installed accessory may be present. If so, carefully remove the accessory connector harness from the accessory connector plug before posi-tapping. It is recommended that all posi-tapping be completed before reattaching the accessory connector harness to the plug.

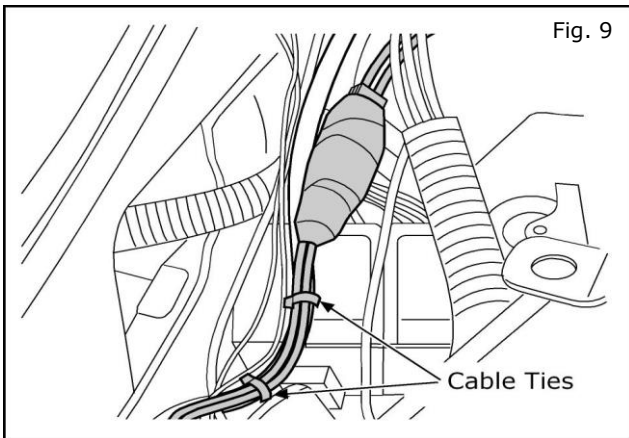

9. Plug the Accessory Connector Harness into the vehicle connector plug on the driver side. Secure with cable ties as shown.

NOTE: Refer to Posi-Tap steps on pages 6 through 8 for proper wire wrapping procedures.

**HARNESS NOT INCLUDED IN KIT.
REFERENCE PART NUMBER 999Q9 AY001.**

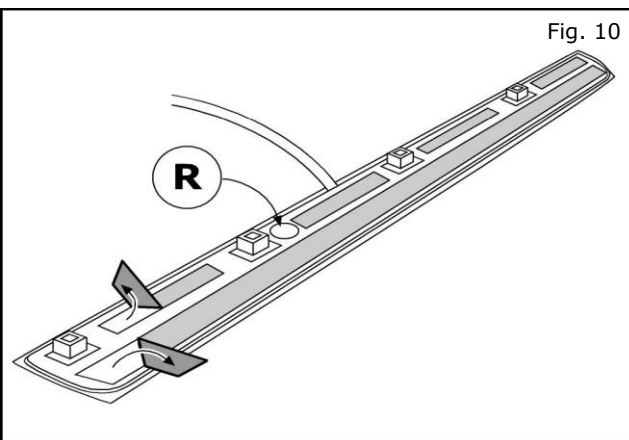

PASSENGER SIDE INSTALLATION

10. Carefully flip the Passenger side Kick Plate over. Partially peel away enough of each adhesive liner to fold down a "flag" that will extend beyond the outer edge of the Kick Plate.

Passenger side kick plate will be marked with an "R"

NOTE: Clean all mounting surfaces with alcohol wipe before final installation.

INSTALLATION INSTRUCTIONS - Illuminated Kick Plate Kit

15. INSTALLATION

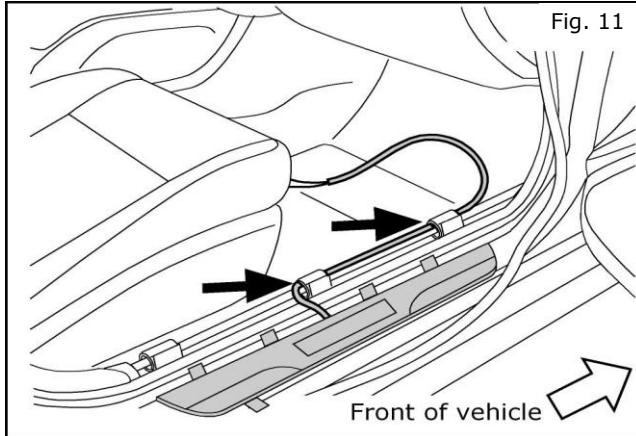

11. Place Illuminated Kick Plate into position on the Passenger side door sill by aligning the clips with the mounting holes in the door sill.

Do not snap the clips into place or close door at this time.

Feed the end of the wiring up through the existing harness clips towards the footwell.

NOTE: Do not remove clear protective film until procedure is complete.

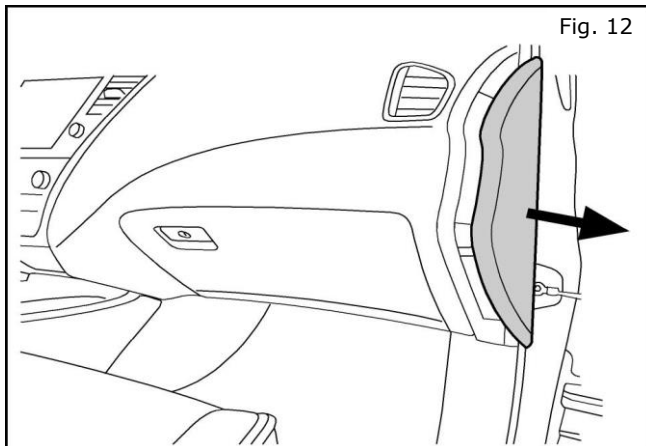

12. Carefully pry off the passenger side dash mask as shown in Fig. 12 using a nylon trim tool.

13. Remove three (3) Torx head screws from the underside of the glovebox.

14. Open the glovebox door. Remove five (5) Torx head screws from inside the glovebox compartment.

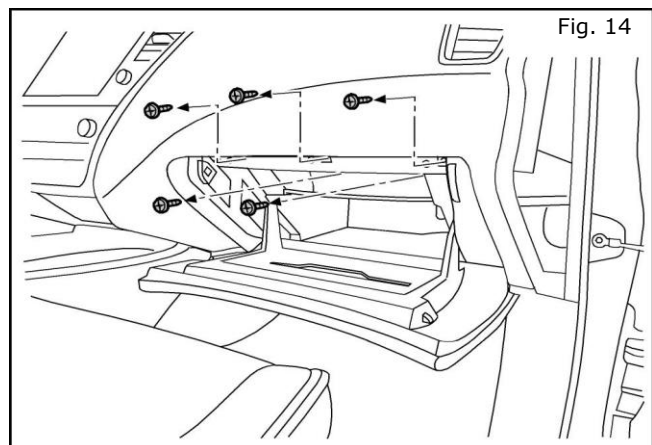
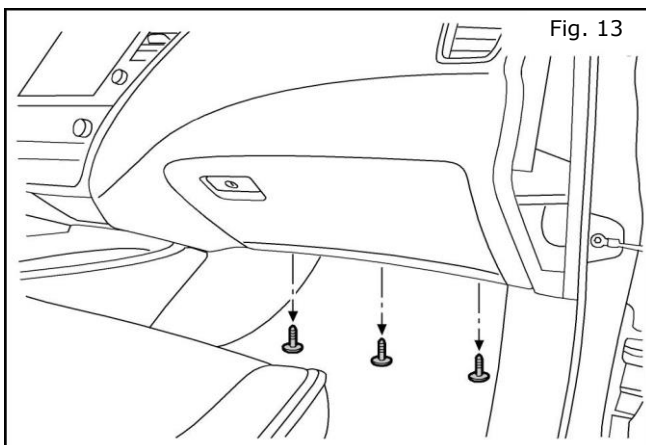

INSTALLATION INSTRUCTIONS - Illuminated Kick Plate Kit

15. INSTALLATION

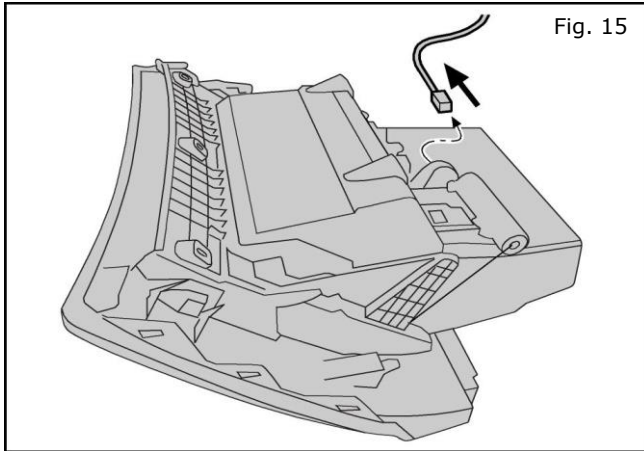

15. Carefully pull out the glovebox assembly. Remove the glovebox lamp. Fully remove the glovebox assembly and set aside.

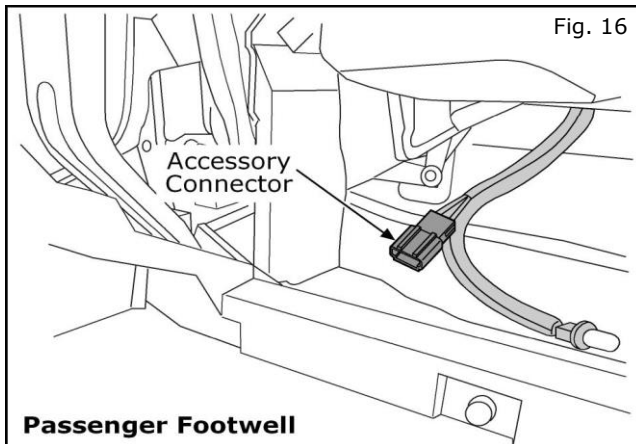

16. Locate the **passenger side** Accessory Connector plug. It will be located in the glovebox opening on the lamp harness.

NOTE: A previously installed accessory may be present. If so, carefully remove the accessory connector harness from the accessory connector plug before posi-tapping. It is recommended that all posi-tapping be completed before reattaching the accessory connector harness to the plug.

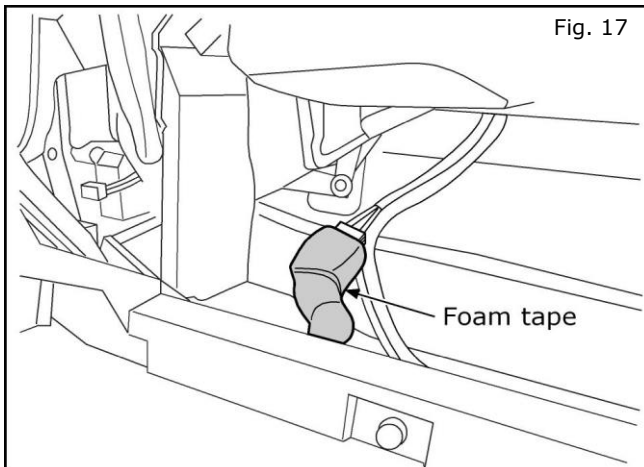

17. **Plug** the Accessory Connector Harness into the vehicle connector plug on the **passenger side**.

NOTE: Review Posi-Tap finishing steps on pages 6 -8 to secure wire bundle.

**HARNESS NOT INCLUDED IN KIT.
REFERENCE PART NUMBER 999Q9 AY001.**

INSTALLATION INSTRUCTIONS - Illuminated Kick Plate Kit

15. INSTALLATION

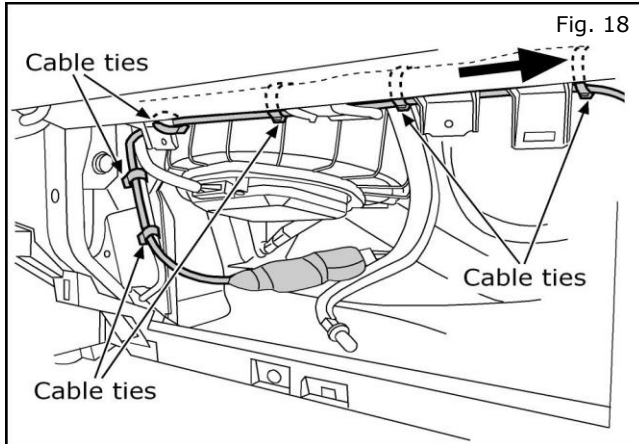

18. Route the **Red** and **Black** wires along the existing harness at the top of the glovebox cavity and out towards the A-pillar. Secure with cable ties as shown.

NOTE: Do NOT secure the wiring to the blower motor housing in any way.

NOTE: A functionality test is recommended at this time. Refer to Check Out procedure on page 17.

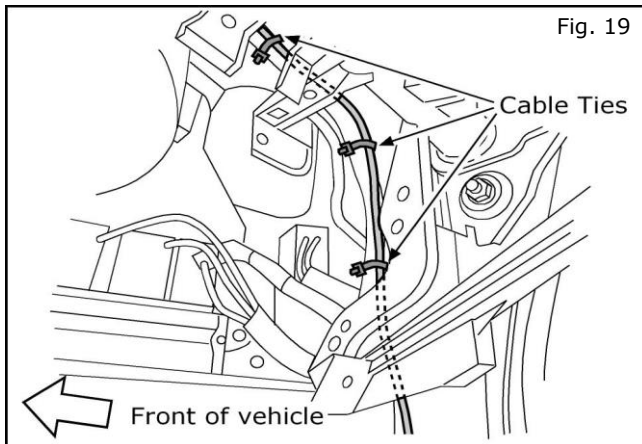

19. Route the **Red** and **Black** wires along the existing harness on the right side of the glovebox cavity and out towards the A-pillar. Secure with cable ties as shown.

NOTE: Be sure to position the new wiring along the outside of the vehicle harness to avoid any contact with the glovebox during reassembly.

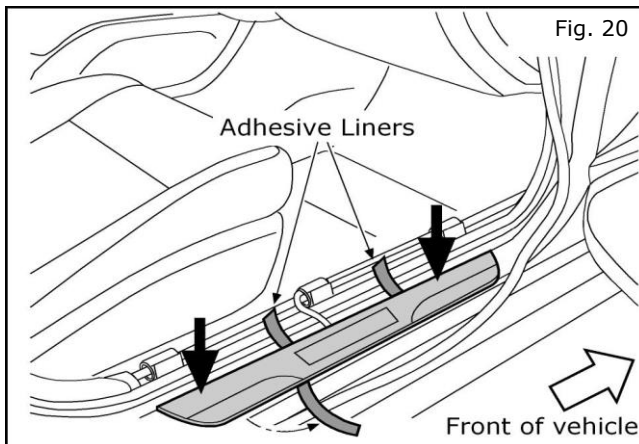

20. Carefully hold the passenger side Kick Plate in position and remove the liners from the adhesive strips.

Apply minimum 15 lbs of downward pressure evenly along the Kick Plate for at least 30 seconds.

INSTALLATION INSTRUCTIONS - Illuminated Kick Plate Kit

15. INSTALLATION

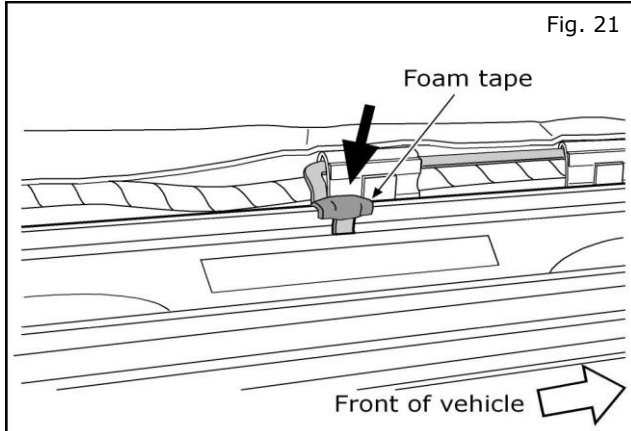

21. Remove all slack from the wiring at the plate end. Carefully bend the wire to fit tightly over the sheet metal edge. Apply foam tape over the wire to prevent squeak and rattle.

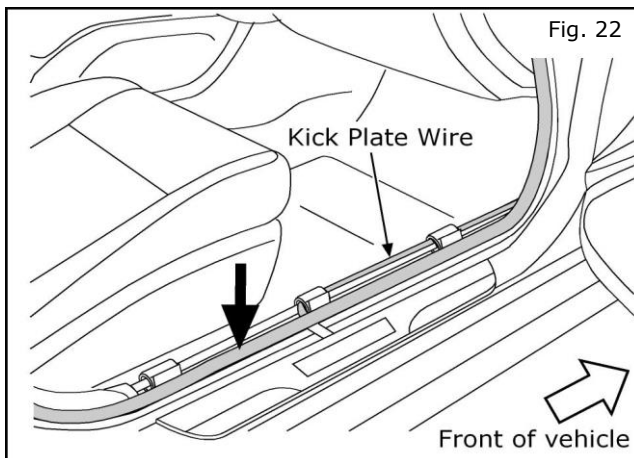
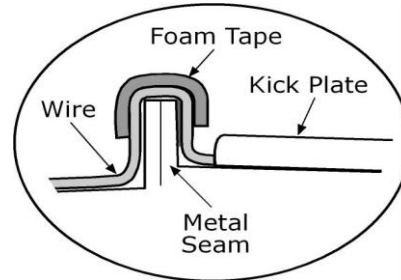

22. Press the door seal welt back down into position. Route the wires along the existing harness.

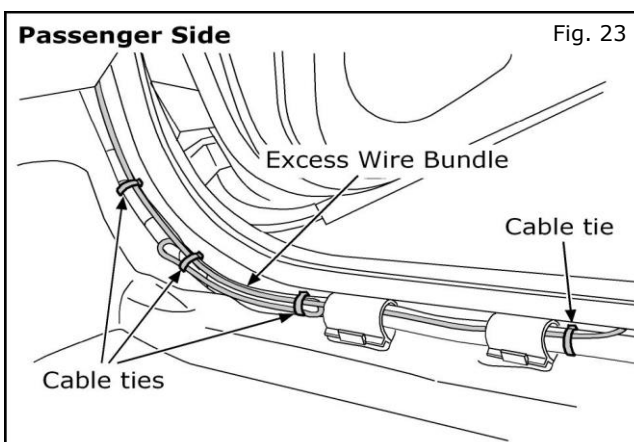

23. On the **passenger side**, bundle any excess wire at the location shown. Secure the Kick Panel wire to the existing harness with cable ties as indicated.

NOTE: Do NOT secure the wiring to the drain tube in any way.

NOTE: This extra wire length is provided in case a particular vehicle build has placed the body harness accessory connector further up inside the Instrument Panel

INSTALLATION INSTRUCTIONS - Illuminated Kick Plate Kit

15. INSTALLATION

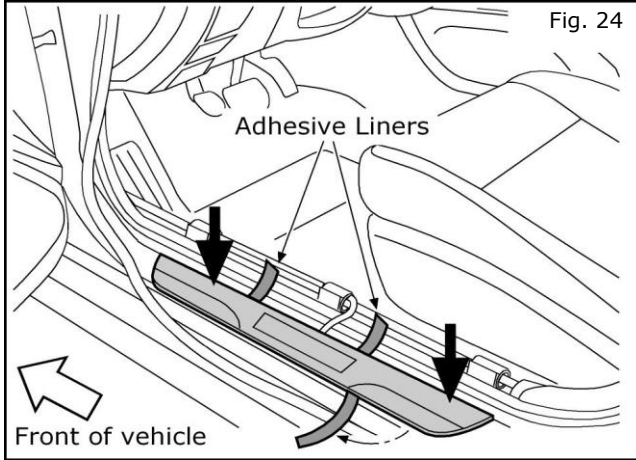

24. **On the driver side**, carefully remove the liners from the adhesive strips. Finish installing the Kick Plate by pressing all the mounting clips into place.

Apply minimum 15 lbs of downward pressure evenly along the Kick Plate for at least 30 seconds.

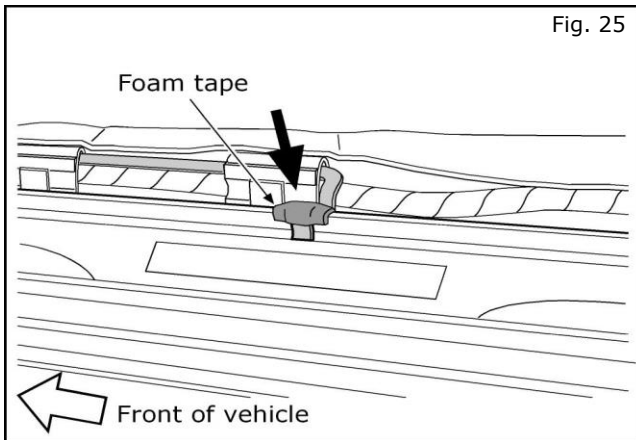

25. Remove all slack from the wiring at the plate end. Carefully bend the wire to fit tightly over the sheet metal edge. Apply foam tape over the wire to prevent squeak and rattle.

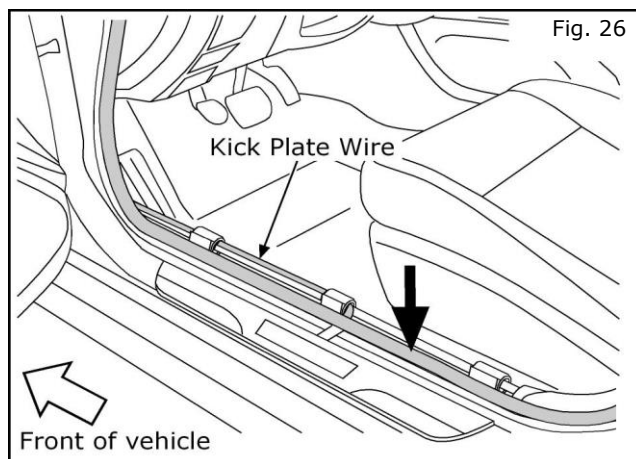
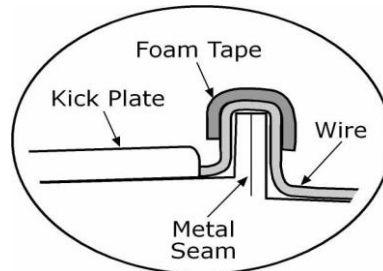

26. Press the door seal welt back down into position. Route the wires along the existing harness.

INSTALLATION INSTRUCTIONS - Illuminated Kick Plate Kit

15. INSTALLATION

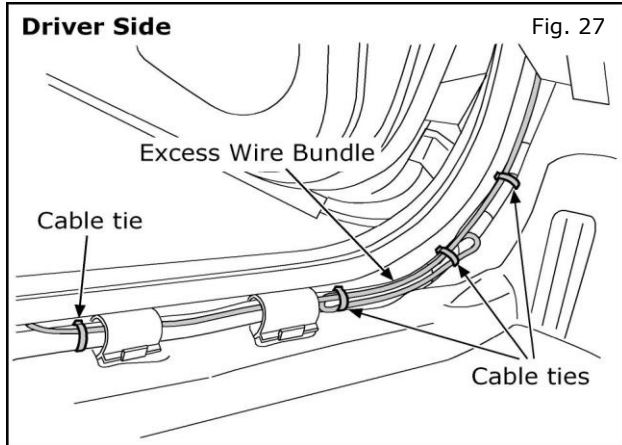

27. On the **driver side**, bundle any excess wire at the location shown. Secure the Kick Panel wire to the existing harness with cable ties as indicated.

NOTE: Do NOT secure the wiring to the drain tube in any way.

NOTE: This extra wire length is provided in case a particular vehicle build has placed the body harness accessory connector further up inside the Instrument Panel

NOTE: Be sure to trim all cable ties. Check all wiring. Make sure all trim is in place and clips are securely fastened.

28. **REVERSE STEPS 1 - 5 TO REINSTALL TRIM PANELS ON BOTH SIDES OF THE VEHICLE.**

INSTALLATION INSTRUCTIONS - Illuminated Kick Plate Kit

15. INSTALLATION

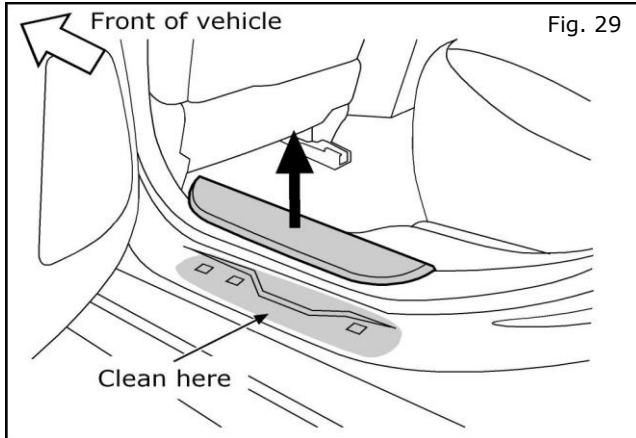

REAR DOORS (NON ILLUMINATED)

29. Use a trim stick to carefully pry off the existing kick plate.

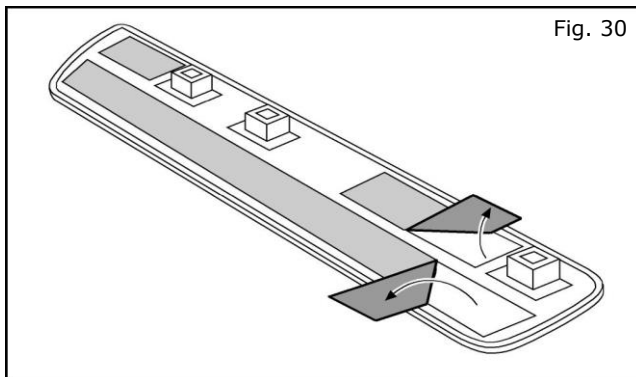

30. Carefully flip the driver rear Kick Plate over. Partially peel away enough of each adhesive liner to fold down a "flag" that will extend beyond the outer edge of the kick plate.

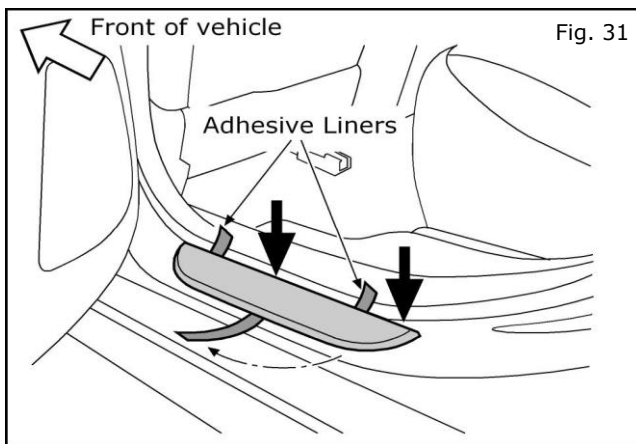

31. Place Rear Kick Plate into position on the driver side door sill by aligning the clips with the mounting holes.

Do not snap the clips into place at this time.

Carefully remove the liners from the adhesive strips. Finish installing the Kick Plate by pressing all the mounting clips into place.

Apply minimum 15 lbs of downward pressure evenly along the Kick Plate for at least 30 seconds.

32. REPEAT STEPS 29 THROUGH 31 FOR THE PASSENGER SIDE.

33. Remove clear protective film from all plates.

NOTE: Make sure all trim is in place and clips are securely fastened.

INSTALLATION INSTRUCTIONS - Illuminated Kick Plate Kit

16. CHECK OUT

Inspect the vehicle for unfinished work.

- (1) Connect battery.
- (2) Do not close doors during this Check Out.
- (3) Verify the Illuminated Kick Plate turns on.
- (4) Push and hold the door status switch located on the vehicles B-pillar.
The kick plate should turn off immediately.
- (5) Repeat steps 3 - 4 with the front right door.
- (6) Verify the functionality of all electrical vehicle components where harnesses were accessed.
- (7) Check and clear any Diagnostic Trouble Codes (DTCs).
- (8) If this vehicle will be returned to a dealer lot or showroom for an extended period of time, be sure the extended storage switch is placed in the "inventory" position.
(Refer to section 9 - Vehicle Preparation)
- (9) If vehicle is NOT going into storage, reset the radio presets to the recorded settings.

Note: When diagnosing electrical system problems, first disconnect the accessory connectors and note effect on system. Continue the investigation with the accessory connectors disconnected. Remember to reconnect the accessories when the investigation is complete.

INSTALLATION INSTRUCTIONS - Illuminated Kick Plate Kit

18. MECHANIZATION

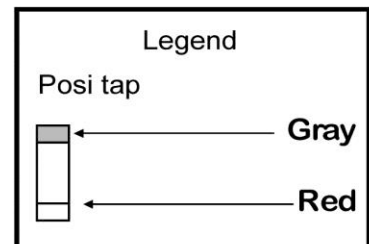
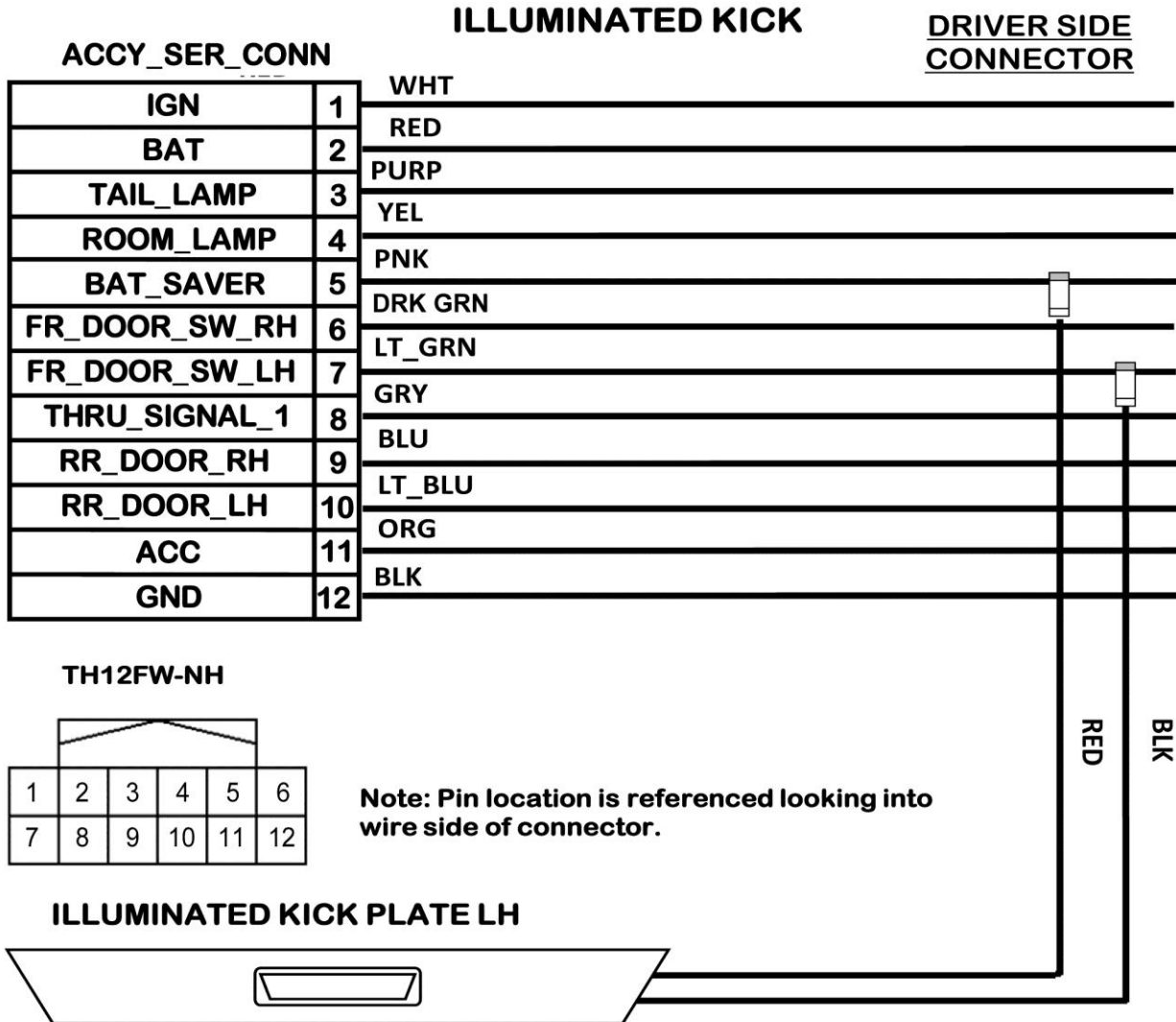

INSTALLATION INSTRUCTIONS - Illuminated Kick Plate Kit

18. MECHANIZATION

